

**ISOMETRIC VIEW
(FRONT)**

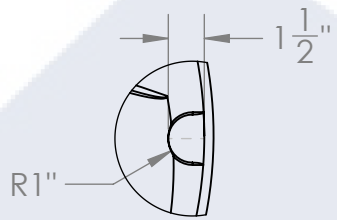

**DETAIL 1C
SCALE 1 : 8**

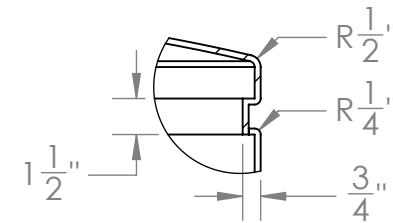

**DETAIL 1A
SCALE 1 : 8**

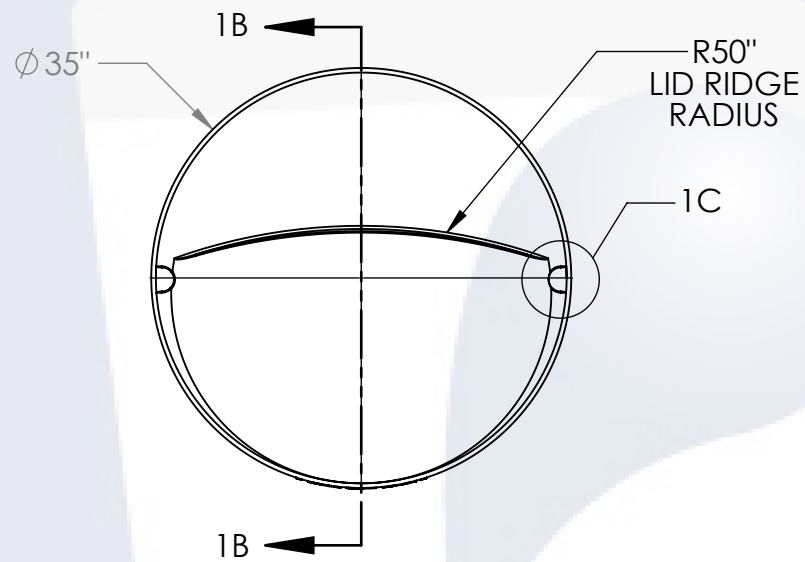

PLAN VIEW

1° LID ANGLE

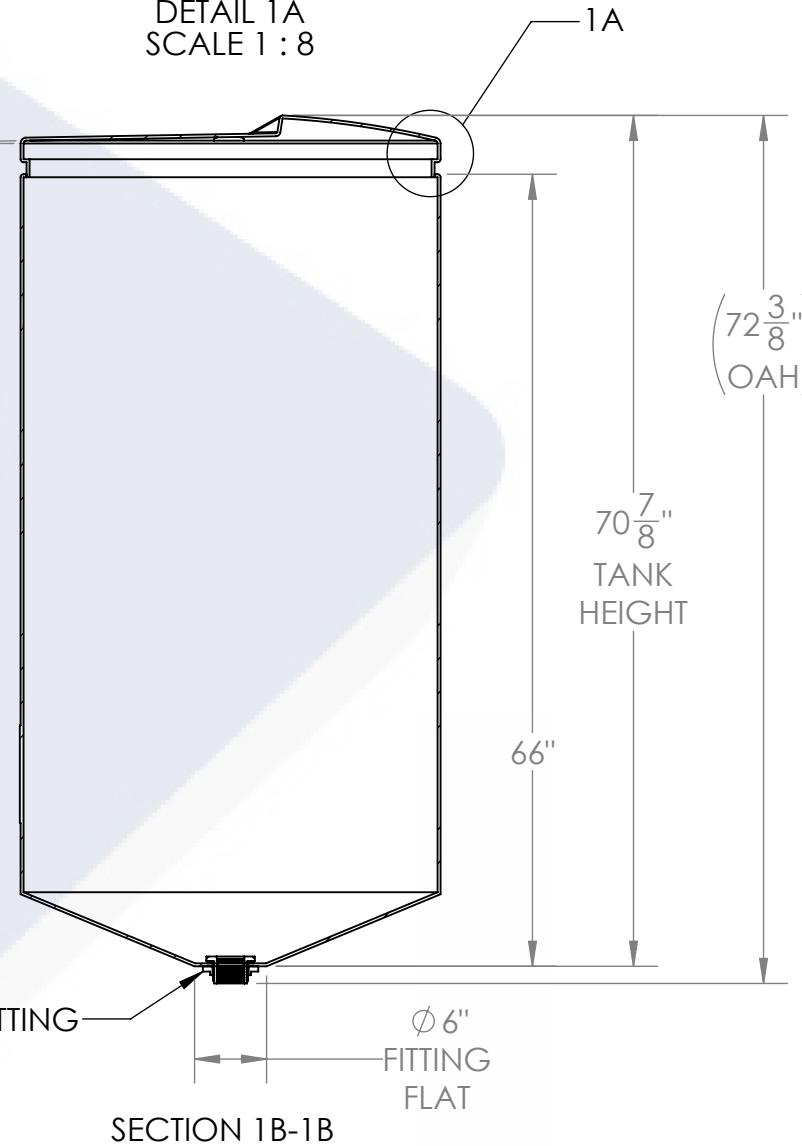

SECTION 1B-1B

- NOTES:**
1. CAPACITY: 250 GAL. NOMINAL
 2. TANK MATERIAL: XLPE
 3. SERVICE PRESSURE: ATMOSPHERIC
 4. NSF/ANSI STANDARD 61 CERTIFIED

PROPRIETARY AND CONFIDENTIAL
THE INFORMATION CONTAINED IN THIS DRAWING IS THE SOLE PROPERTY OF PEABODY ENGINEERING. ANY REPRODUCTION IN PART OR AS A WHOLE WITHOUT THE WRITTEN PERMISSION OF PEABODY ENGINEERING IS PROHIBITED.

UNLESS OTHERWISE SPECIFIED:

DIMENSIONS ARE IN INCHES
TOLERANCES: ±1/4"
ANGULAR: ± .5°
ONE PLACE DECIMAL: ± .25
TWO PLACE DECIMAL: ± .125
THREE PLACE DECIMAL: ± .063

TANK MATERIAL:

INNER TANK S/N:

OUTER TANK S/N:

CUSTOMER PO#

DO NOT SCALE DRAWING

	NAME	DATE
DRAWN	SMF	03/01/23
CHECKED		
ENG APPR.		
MFG APPR.		
Q.A.		

			PROJECT:	PROCHEM® TANKS	
			CUSTOMER:	PEABODY STANDARD	
			SITE/LOCATION:	-	
			SALES ORDER:	-	
SIZE	DESC.		REV.		
B	250GAL CONE BOTTOM TANK		B		
SCALE: 1:16			SHEET 1 OF 1		